

# PRODUCT DATA

COMFORT 1200 BY NILAN



## Ventilation & passive heat recovery



Commercial



Passive  
heat recovery



Ventilation  
<math>< 1400 \text{ m}^3/\text{h}</math>

# COMFORT 1200

The Comfort 1200 is a ventilation unit suitable for central ventilation of residential buildings, schools, offices and business facilities with a ventilation requirement of up to 1400 m<sup>3</sup>/h.

Every component has been carefully selected with a view to unsurpassed quality and each component is tested throughout the entire production process, as are the finished units before leaving the factory. This quality control reflects our high standards, which not only exceed market requirements but also take them several steps further.

## Automatic control

The Comfort 1200 is supplied with an integrated CTS 602 control, which is operated by the enclosed control panel.

The modern CTS 602 control communicates Modbus RTU RS485. A CTS system using this type of communication can easily be connected to the device.

## Filters

The Comfort 1200 is supplied with bag filters. An M5 filter in the air exhaust and an F7 filter for fresh air are supplied as standard.

The CTS 602 control has a built-in timer controlled alarm for change of filter. It is possible to install a pressure controlled filter monitor (accessorie).

## Doors

The large doors allow easy access for the changing the filters, as well as for servicing of the unit.



## Modulating bypass

An automatic bypass valve directs the fresh air past the heat exchanger when waste heat recovery is not necessary, thus conserving energy.

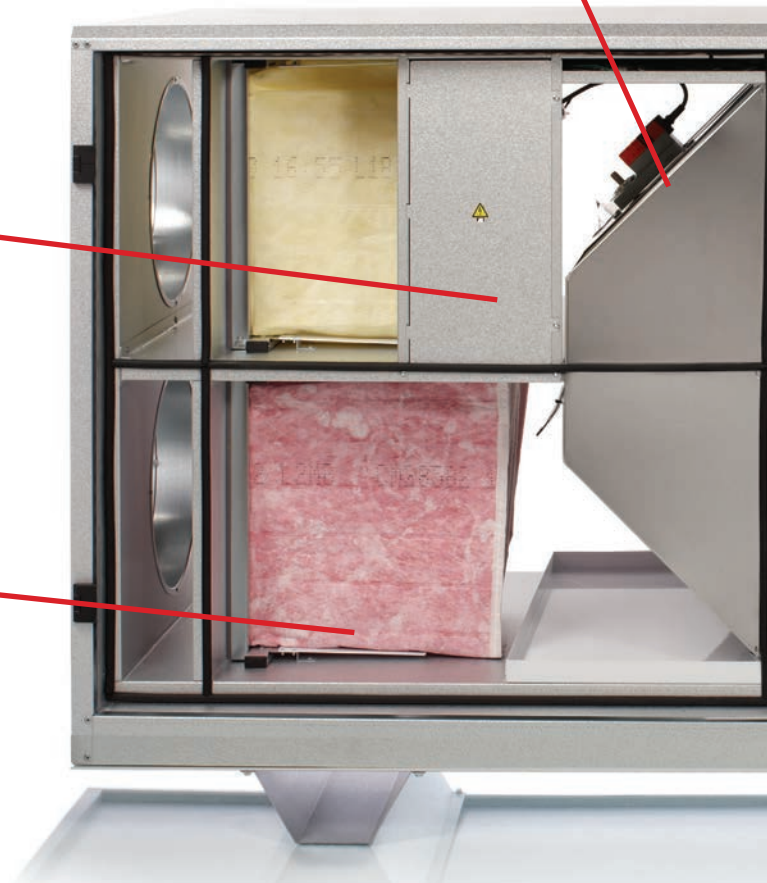

## Frost protection

An electric heater can be purchased for frost protection. This prevents the formation of ice in the counterflow heat exchanger in the event of long periods of frost.



**Counterflow heat exchanger**

Heat recovery is achieved by two counter flow heat exchangers made of highly corrosion resistant marine aluminium. The counterflow heat exchangers have an energy efficiency of more than 80% and prevent odours being transferred from the extracted air to the supply air.

The CTS 602 control allows for cooling recovery.

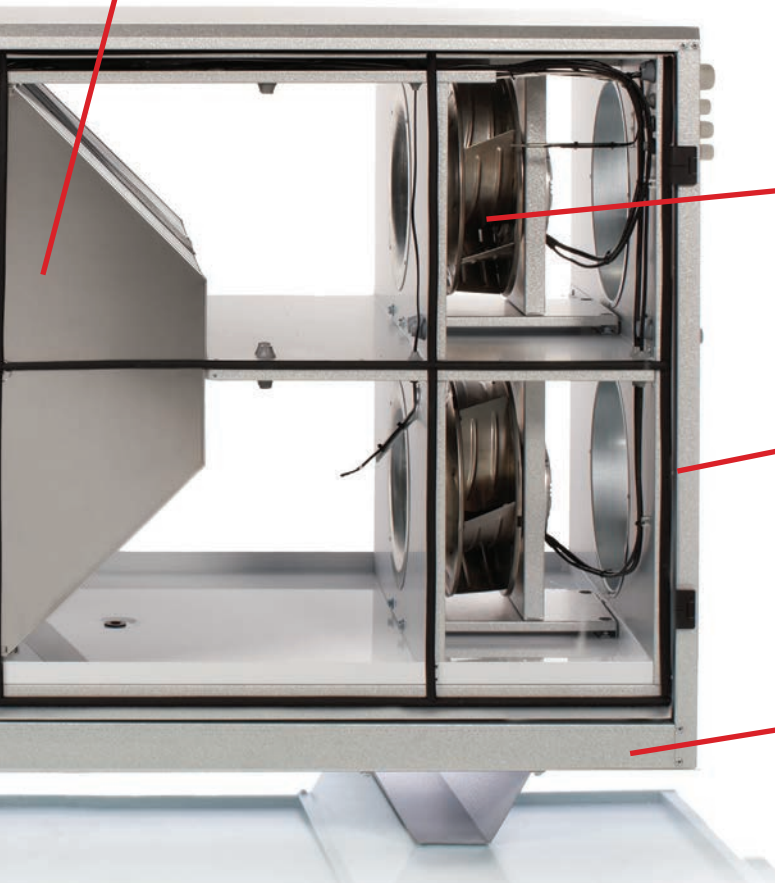

**Plug fans**

The two fan sections consist of energy-efficient EC motors with built-in motor controllers operated by a 0-10V signal.

The efficient fan wheels have rear facing impellers and are extremely quiet.

**Construction**

The Comfort 1200 is housed in a strong frame structure of Aluzinc with 50 mm insulation.

**Base**

The Comfort 1200 is delivered with a robust, built-in base.

**Heating elements**

External water or electric heating elements, regulated by the CTS 602 control, can be purchased.

The water-heating surface can be built into the unit.

**Pressure control**

The extraction and/or supply fan can be operated with the aid of a pressure transmitter.



# COMFORT 1200

## Technical specifications

Dimensions (W x D x H)	1815 x 825 x 970 mm
Weight	380 kg
Min. Airvolume	400 m <sup>3</sup> /h
Max. Airvolume	1400 m <sup>3</sup> /h
Power consumption	500W
Power supply	230 V (±10 %), 50/60 HZ
Max. phase	13 A
Standby power	4 W
Plate type casing	Aluzinc steel plate
Heat exchanger type	Aluminium counterflow heat exchanger
Filter class	Standard bagfilters M5 Extract air and F7 Fresh air
Duct connections	Ø 315 mm
Condensate drain	PVC, Ø 20x1.5 mm
External leakage underpressure (*1)	< 1.45 %
External leakage overpressure (*2)	< 2.14 %
Internal leakage (*3)	< 2.90 %
Tightness class	IP31

\*1 At ± 250 Pa and 1200 m<sup>3</sup>/h according EN 308/EN 13141-7.

\*2 At ± 100 Pa and 1200 m<sup>3</sup>/h according EN 308/EN 13141-7.

\*3 At ± 100 Pa and 1200 m<sup>3</sup>/h according EN 308/EN 13141-7.

## Motor and motor control

Motor type	EC-Engine
Motor class in accordance with IEC 60034-30	IE3 (Premium efficiency)
Voltage input	1 x 230 V
Current overload protection	Built-in
Control signal with third party control system	0 - 10 V DC
Fluid temperature (air)	-20 / +40 °C
Ambient temperature (operating)	-20 / +40 °C

## Functional diagram

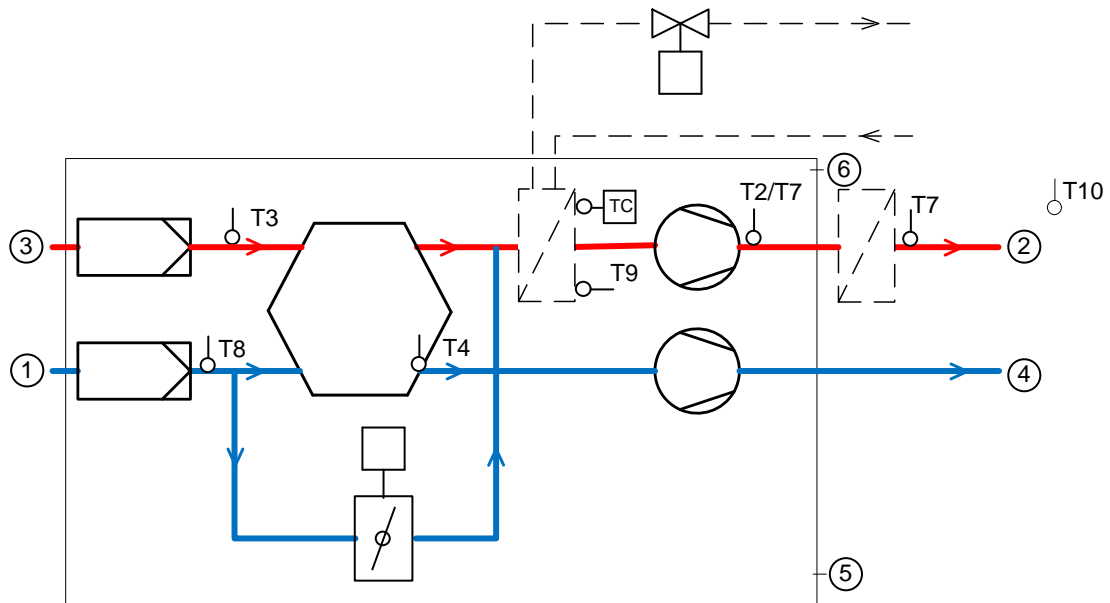

### Connections

- 1: Fresh air
- 2: Supply air
- 3: Extract air
- 4: Discharge air
- 5: Condensate drain
- 6: Electric and water heating

### Automation

- T2/T7: Supply air sensor
- T9/TC: Heating element frost protection
- T3: Extract air sensor
- T4: Discharge air and defrost sensor
- T8: Fresh air sensor
- T10: Room sensor

# PLANNING DATA

Nilan units are tested in accordance with the valid standards of accredited independent test institutes.

## Capacity

Capacity of standard unit as a function of  $q_v$  and  $P_{t,ext}$ .

SFP values according to EN 13141-7 are for standard units with M5-filter in extract air, F7-filter in fresh air and no heating element.

SFP values comprise the unit's total power consumption incl. control.

Conversion factor:  $\frac{J/m^3}{3600} = W/m^3/h$

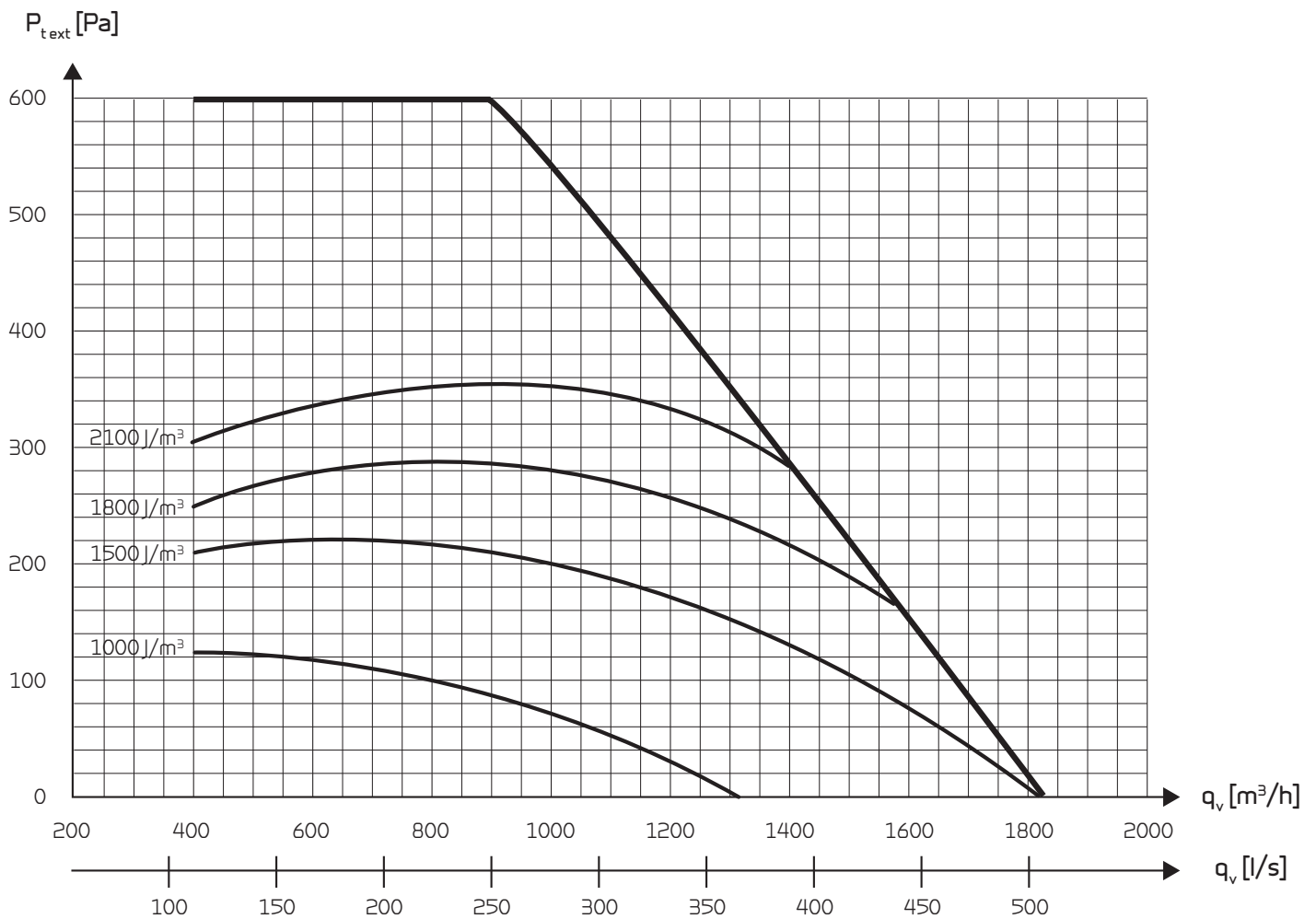

## Temperature efficiency

Temperature efficiency for unit with counterflow heat exchanger according to EN308 (dry).

Temperature efficiency EN308:  $\eta_t = (t_{\text{supply air}} - t_{\text{fresh air}}) / (t_{\text{extract air}} - t_{\text{fresh air}})$

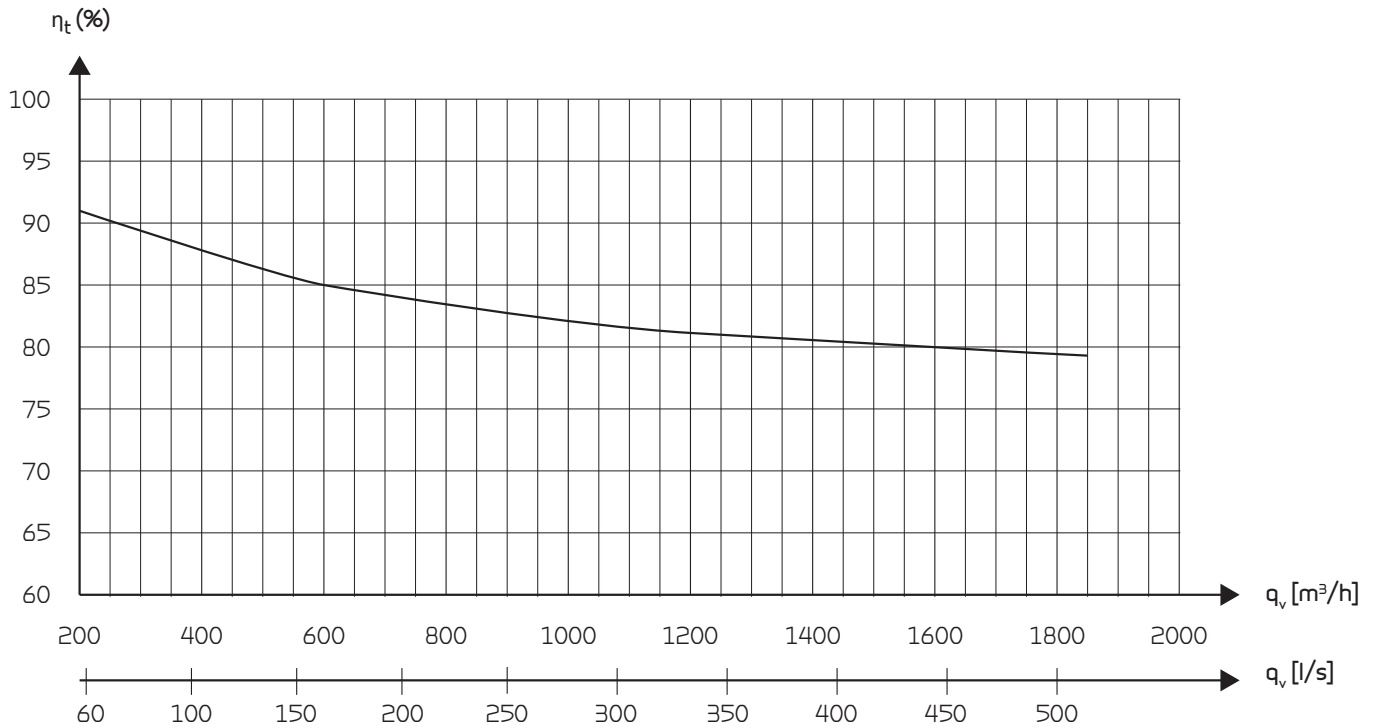

## Sound data

Sound data for  $q_v = 1200 \text{ m}^3/\text{h}$  and  $P_{t, \text{ext}} = 250 \text{ Pa}$  according to EN 9614-2 for surfaces and EN 5136 for ducts.

Sound output level  $L_{\text{WA}}$  drops with falling air volume and falling back pressure.

Sound output level  $L_{\text{pA}}$  at a given distance will depend on acoustic conditions in the place of installation.

### Sound output level ( $L_{\text{WA}}$ )

Oktavband Hz	Surface dB(A)	Supply air dB(A)	Extract air dB(A)	Fresh air dB(A)	Discharge air dB(A)
63	48	66	58	59	65
125	46	63	57	58	63
250	44	69	64	66	68
500	33	69	60	61	67
1.000	26	71	54	54	71
2.000	27	71	50	51	72
4.000	28	66	47	47	69
Total $\pm 2$ dB(A)	51	77	67	69	77

# PLANNING DATA

## Heating elements (accessory)

### Water heating element (for internal fitting)

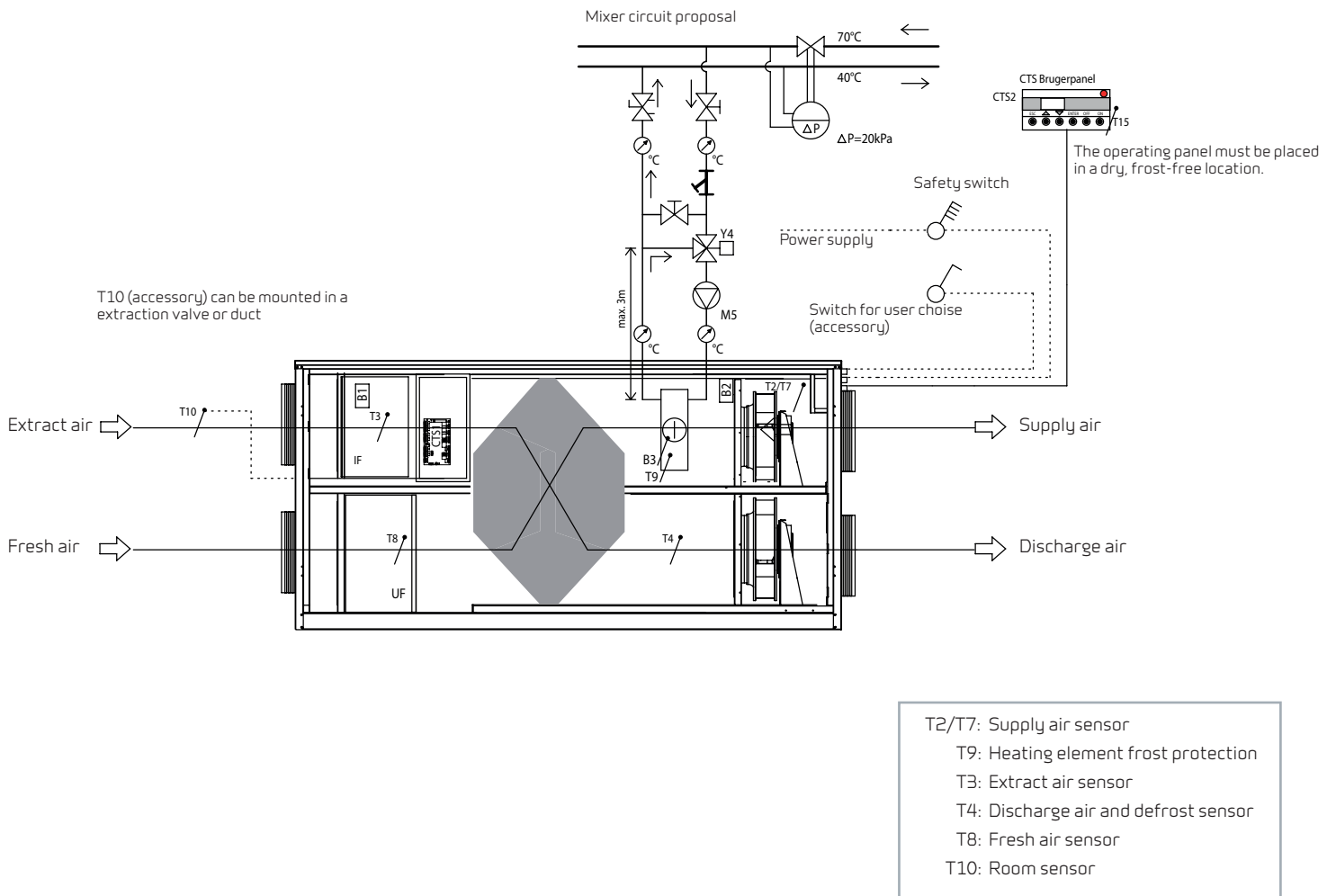

## Electrical heating element (duct mounted)

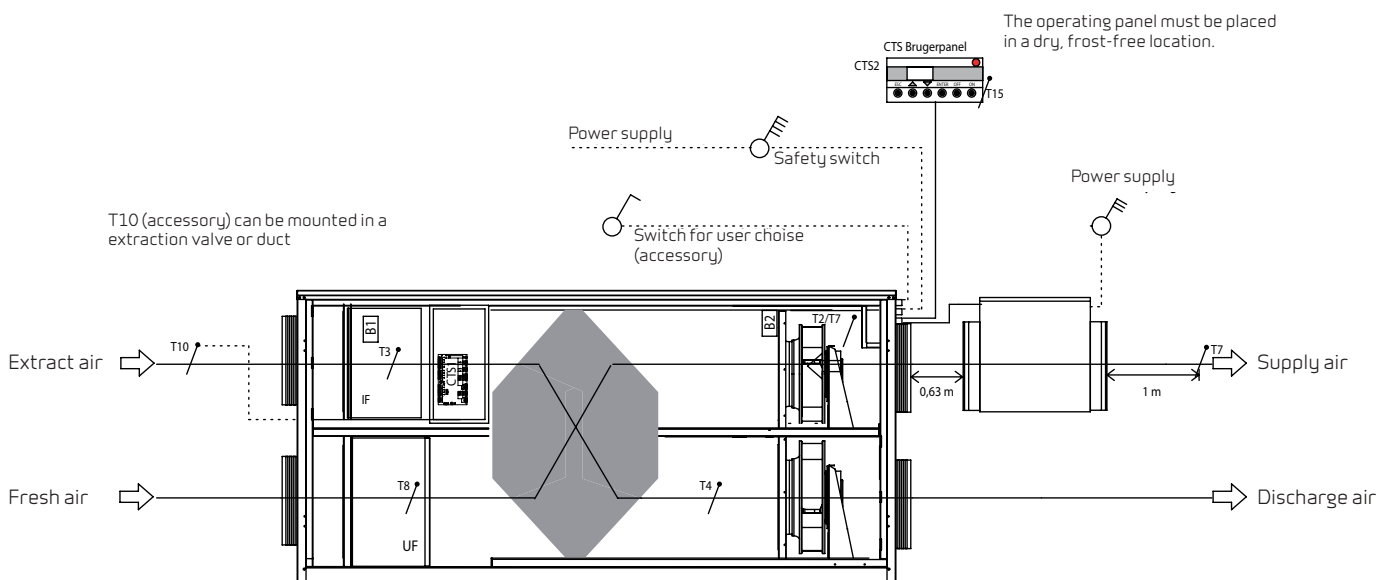



## Capacity - Heating element (accessory)



### Electrical heating surface

The electrical heating surface is fitted in the air inlet duct at a distance of min. 2 x duct diameter from the system's fresh air inlet connection pipe (normally min 400 mm.) and connected to the CTS 602 control panel and 3 x 400 V supply.

The electrical heating surface can supply up to 6 kW of heat.



### Water heating element for internal fitting

The water heating element is designed to be built into the system and must be connected to the primary heating supply and the CTS 602 control. The water heating element includes copper pipes and aluminium fins.

Capacities can be seen in the table below.

### Capacity water heating element

Temperature input/output [°C]	Water side			Air side			
	Flow [l/h]	Pressure drop [kPa]	Output [kW]	Flow [m³/h]	Temperature before WHE* [°C]	Temperature after WHE* [°C]	Pressure drop over WHE* [Pa]
40/30	156	2.2	1.8	400	16	29.2	4.2
	206	3.6	2.4	600	16	27.7	8.1
	249	5.1	2.9	800	16	26.6	13.0
	286	6.6	3.3	1000	16	25.7	18.7
	319	8.0	3.7	1200	16	25.0	25.2
	350	9.5	4.1	1400	16	24.5	32.4
60/40	142	1.8	3.3	400	16	40.0	4.2
	188	2.9	4.3	600	16	37.1	8.1
	226	4.1	5.2	800	16	35.1	13.0
	260	5.2	6.0	1000	16	33.5	18.7
	290	6.4	6.7	1200	16	32.3	25.2
	318	7.5	7.3	1400	16	31.3	32.4
70/40	107	1.0	3.7	400	16	42.9	4.2
	140	1.7	4.8	600	16	39.5	8.1
	168	2.3	5.8	800	16	37.2	13.0
	192	3.0	6.6	1000	16	35.4	18.7
	214	3.6	7.4	1200	16	34.0	25.2
	234	4.2	8.1	1400	16	32.9	32.4

\* Water heating element.

# AUTOMATION

## CTS602 Control



The Comfort 1200 is controlled using its CTS 602 operating panel, featuring a wide range of functions, e.g., menu-controlled operation, weekly programme settings, filter monitor with timer, fan speed adjustment, summer bypass (free cooling), post-heating element control, error messages etc.

The CTS 602 comes with factory settings, including a default setting which can be customised to operational requirements to achieve optimum operation and utilisation of the system.

The operating panel must be placed in a dry, frost-free location, at least 1.5 m above floor level and at least 0.5 m from any corner. Avoid placing the panel on an external wall or in areas in direct sunlight.

Operating instructions for the CTS 602 can be found in a separate user manual supplied with the unit.

## External communication

The CTS 602 control unit communicates by default with Modbus RTU RS485 communication. A CTS system using this form of communication can easily be connected to the unit.

Nilan units have an open Modbus communication, i.e. not only can the unit be monitored, but its operation can also be set in the same way as it can via the operating panel.

The protocol is set up by default for a Modbus RTU 30 address, but can be set to a value between 1 and 247.

A Modbus converter allows you to connect one or more units to a computer to monitor and control the unit.

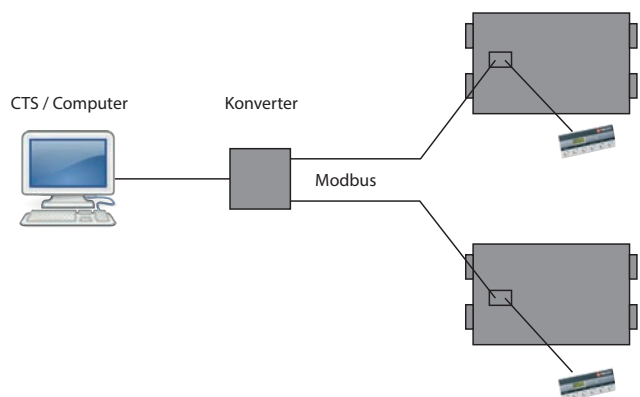

Functional overview		+ Standard - Accessories
3 levels	The control function is divided into 3 levels: User/Service/Factory with various options at each level	+
Weekly plan	There is an option for you to set your own weekly programme.	+
User option 1	This allows you to override the operating mode in the main menu via an external potential-free contact or PIR sensor.	+
Alarms	Alarm log featuring the last 16 alarms.	+
Filter monitor	Filter monitor with timer (factory setting of 90 days). Adjustable to 30/90/180/360 days.	+
Pressure controlled filter monitor	It is possible to purchase Comfort 1200 with a pressure controlled filter monitor	-
Bypass	Bypassing the outdoor air reduces heat recovery, enabling the desired supply air temperature to be maintained spring, summer and autumn.	+
Air quality	Allows you to choose whether to switch humidity sensors and/or CO <sub>2</sub> sensors on and off.	-
Humidity control	Allows you to set a higher or lower ventilation step in the case of high/low air humidity.	-
CO <sub>2</sub> control	Allows you to set a higher or lower ventilation step in the case of a high/low CO <sub>2</sub> level.	-
Air exchange	Allows you to select a low ventilation step in the case of low outside temperatures and air humidity.	+
Defrost function	Temperature-based automatic function for defrosting the heat exchanger.	+
Frostprotection	In case of failing heating system, the unit is turned off to avoid further cooling with a risk of the water heating coil frost bursting.	+
Temperature control	Allows you to select the temperature sensor which will control the unit. • T15 ROOM (panel sensor) • T10 EXT (fitted in a representative extraction valve) • T3 EXTRACT (extract air)	+/-
Room low	Stops the unit at a low room temperature. Hereby is cooling of the home avoided in case of a failing central heating system. Standard set to OFF. Can be set from 1 to 20 degrees and is controlled by: • T15 ROOM (panel sensor) • T10 EXT (fitted in a representative extraction valve) • T3 EXHAUST (extract air)	+
Room control	Allows you to set the regulator to control the room temperature.	+
Air volume	Allows you to set four ventilation steps. Supply air and extract air are set individually. Step 1 < 25% - Step 2 < 45% - Step 3 < 70% - Step 4 < 100%	+
Fire alarm	This allows you to connect fire-detecting thermostats, smoke detectors and other fire alarm contacts. In case of an alarm, smoke dampers are closed and the unit stops.	+
Joint alarm	Outlet for joint alarm	+
Constant pressure control	Allows control from both the extract air and supply air side.	-
Cooling	Via bypass. This allows you to choose whether to run the system at a higher or the highest ventilation step during cooling. The weekly programme has an option for setting cooling at night.	+
Intake air control	Allows you to set the regulator to control the intake air temperature/supply air (only available if the control unit has been configured for a supply-heating element).	+
External heating element	• Temperature sensor T7 is an supply air sensor • Integrated frost protection for external water heating element • Motorised valve and circulation pump control unit	-
External electric heating element	• Temperature sensor T7 is an supply air sensor • Overheating protection	-
Delayed start-up	There is a possibility for a delayed start-up by the fans, when a closing damper is installed.	+
Expansion PCB	Allows you to make additional connections, e.g. • User option 2 overrides User option 1 (e.g. connecting an EM box) • Up to 500 W direct • Can give the signal for external heating if the defrost function is used • Switching the central heating system on/off	-
Reset	Allows you to restore the factory settings.	+
Manual test	Allows you to test the unit's functions manually.	+
Language	Option for setting the relevant language (Danish/Finnish/Norwegian/Swedish/German/English/French).	+

# OPERATION

## Frost protection

All ventilation units with a counterflow heat exchanger will ice up if the outdoor temperature is below freezing for a prolonged period.

The extracted air condenses when it is cooled down during heat recovery. The high temperature efficiency will slowly turn the condensate to ice, which will block up the counterflow heat exchanger unless action is taken to remedy this.

Consideration must be given to whether the unit's operation can be protected during a lengthy period of frost or whether it is acceptable to decrease its operation.

In homes which are occupied at night, it would be advisable to protect the unit against frost when the outdoor temperature is coldest by using a pre-heating element. On the other hand, if the ventilation is for an office, it may be acceptable to decrease the operating level at night.

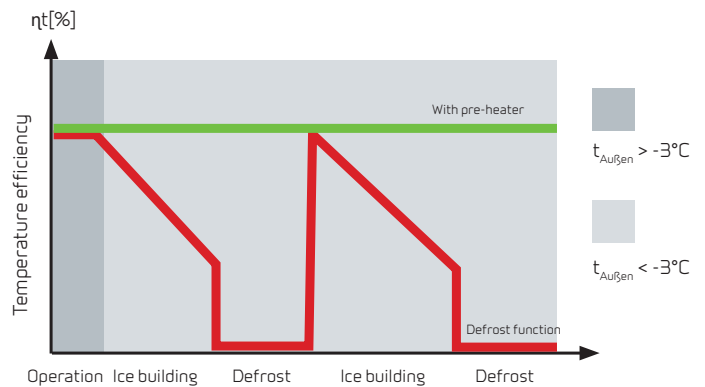

The energy used for the preheating is not wasted, as it ensures a constant high temperature efficiency

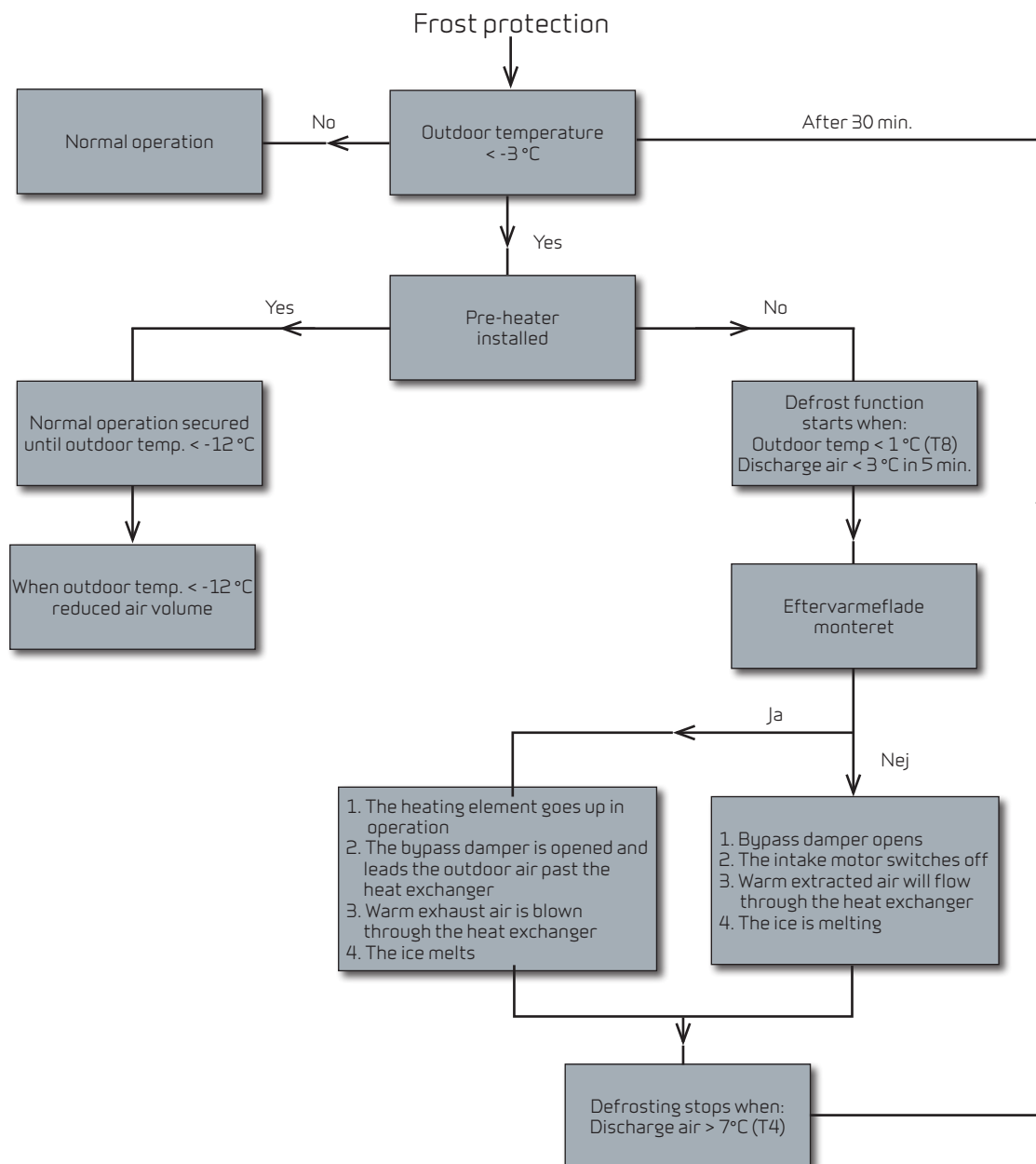

# DIMENSIONAL DRAWING

COMFORT 1200 BY NILAN

Right model

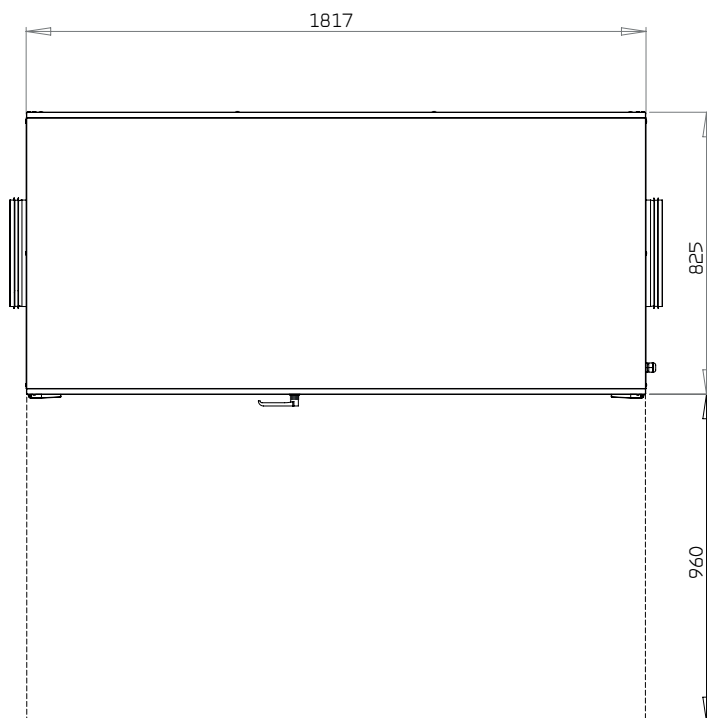
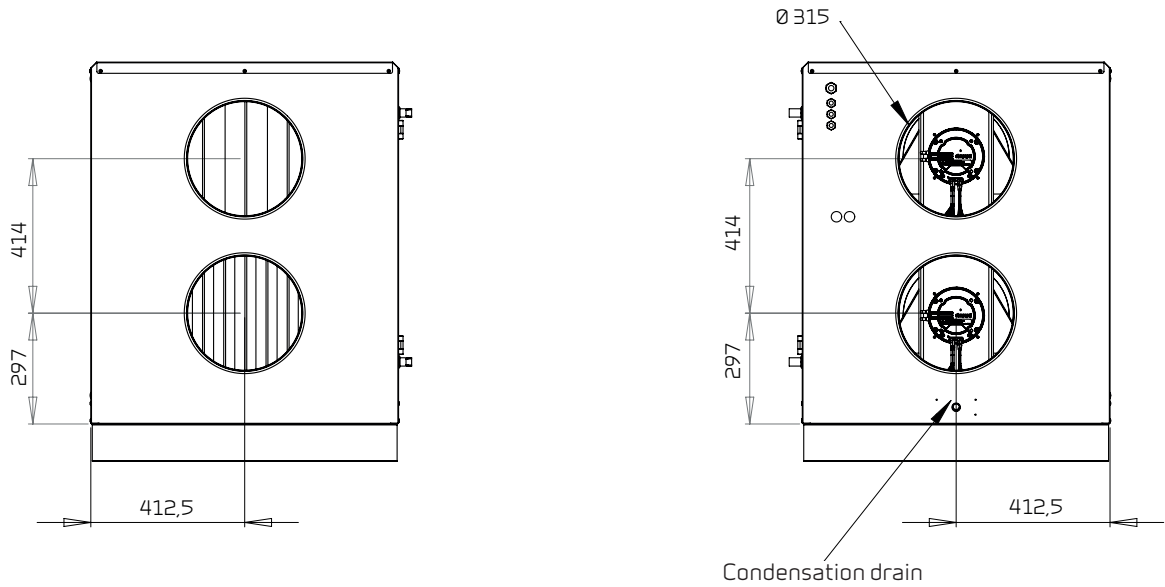
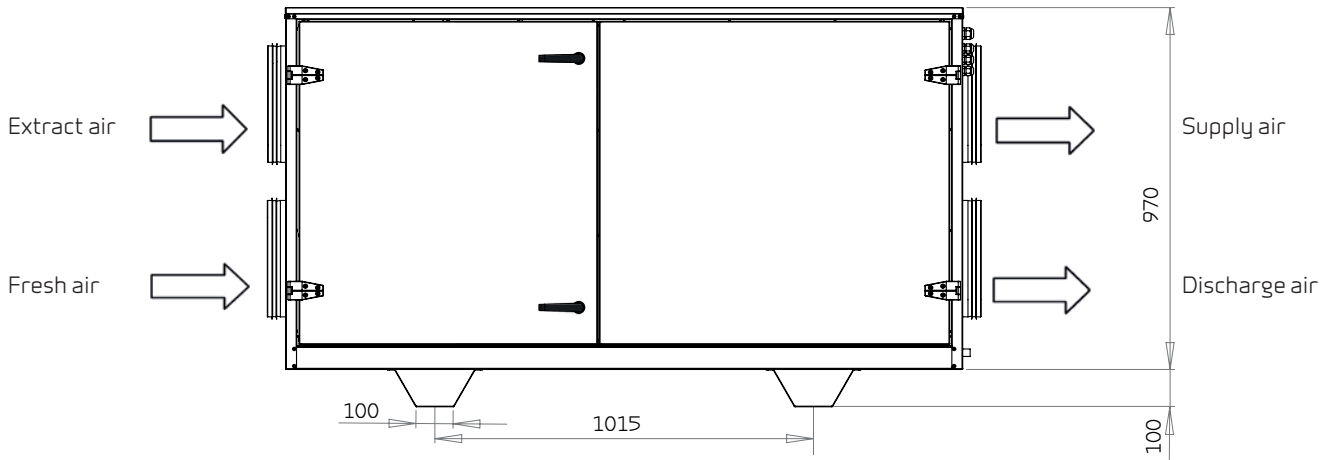

# ACCESSORIES

## Top cover

If Comfort 1200 is going to be installed outside, it is possible to order a top cover which protects the unit against rain and snow.



## Pressure transmitter

The extraction and/or supply fan can be operated with the aid of one or two pressure transmitters.

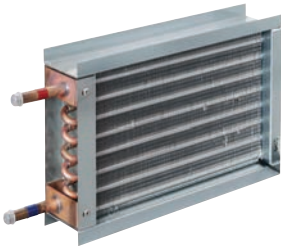

## Water heating element incl. regulation

The supply temperature can always be raised to the required level using a water heating element. The water heating element is designed to be built into the unit and must be connected to the primary heating supply. Supplied with two-way adjustment valve, temperature sensor and frost thermostat.



## Electrical heating surface incl. regulation

When you fit an electrical heating surface, you can raise the fresh air temperature to the desired level at any time. The electrical heating surface is supplied ready to fit into the fresh air duct and, for easy fitting, the device is pre-fitted with all the required sensors.



## Electrical pre-heating element (Frost protection)

An electrical pre-heating element heats up the outdoor air before it enters the unit. This avoids having to defrost the unit, resulting in a loss of power. There are temperature sensors supplied to be fitted in the ducts.



## Expansion PCB

The expansion PCB provides additional functions for the CTS 602 control unit, e.g., controlling the EM-box (see list of functions on page 7).

## Installationset

Vibration absorbers and a water trap for the condensation outlet.



## Heating cable

To protect the condensation outlet against frost, a 3 metre-long self-regulating heating cable can be ordered.

# DELIVERY AND HANDLING

## Transport and storage

Comfort 1200 comes in factory packaging that protects it during transport and storage. Comfort 1200 must be stored in a dry place in its original packaging until installation.

The packaging should only be removed immediately prior to installation.

## Installation conditions

During installation, future service and maintenance should be taken into account. We recommend a minimum gap in front of and behind the unit of 96 cm.

The unit must be installed level for the sake of the condensate drain. The condensate drain requires clearance of min. 12,5 cm under the drain nozzle.

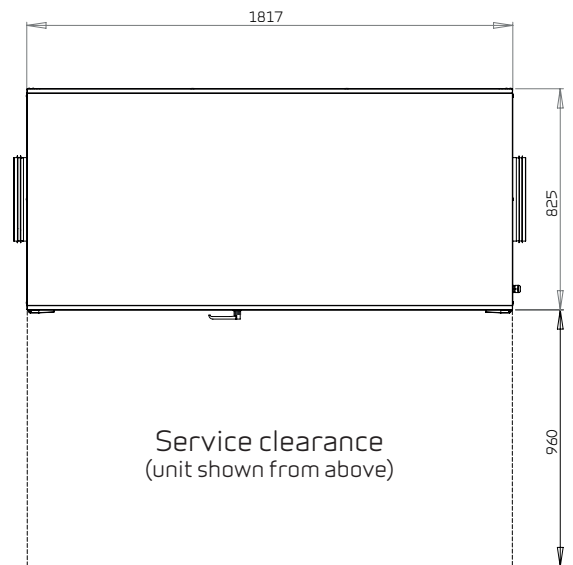

## Installation of electric heating element

Electric heating elements (accessories) are fitted in the duct. The fitter should ensure that there is a safe distance of at least 15 cm between the electric heating element and any inflammable material. The heating element must be insulated using fire-resistant insulation material.

The electric heating element must be connected by an authorised electrician.

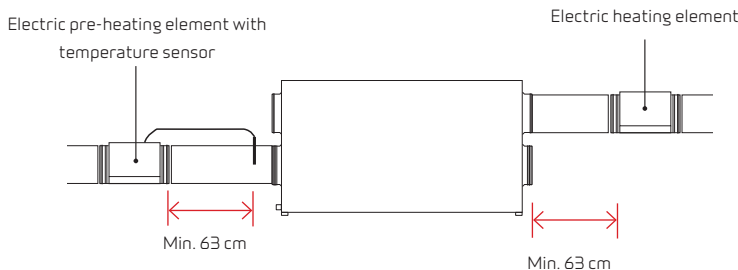
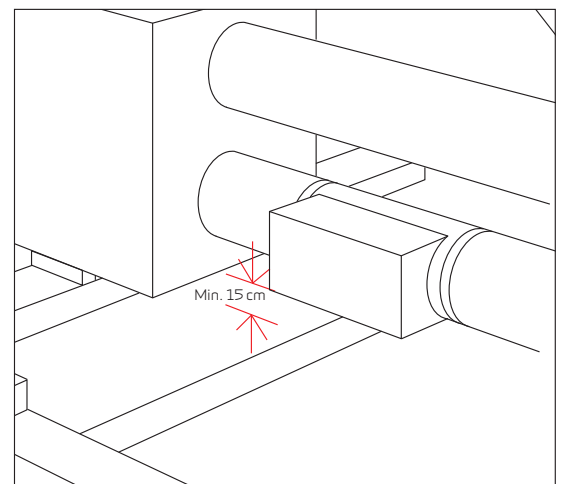

# INFORMATION FROM A TO Z

Nilan develops and manufactures premium-quality, energy-saving ventilation and heat pump solutions that provide a healthy indoor climate and low-level energy consumption with the greatest consideration for the environment. In order to facilitate each step in the construction process - from choosing the solution through to planning, installation and maintenance - we have created a series of information material which is available for download at [www.nilan.dk](http://www.nilan.dk).



**Brochure**  
General information about the solution and its benefits.



**Product data**  
Technical information to ensure correct choice of solution.



**Installation instructions**  
Detailed guide for installation and initial adjustment of the solution.



**User manual**  
Detailed guide for regulation of the solution to ensure optimum day-to-day operation.

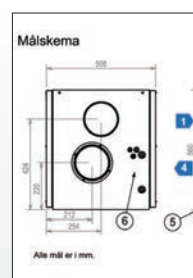

**Drawings**  
Tender documents and 3D drawings are available to download for planning purposes.

[WWW.NILAN.DK](http://WWW.NILAN.DK)

Visit us at [www.nilan.dk](http://www.nilan.dk) to find out more about our company and solutions, download further information and find your nearest dealer.



Nilan A/S  
Nilanvej 2  
8722 Hedensted  
Danmark  
Tlf. +45 76 75 25 00  
Fax +45 76 75 25 25  
[nilan@nilan.dk](mailto:nilan@nilan.dk)  
[www.nilan.dk](http://www.nilan.dk)